

**160094 Dimensions**

Overall Width w/ Trim: 20-5/16"  
(Rough Opening: 18-1/16")

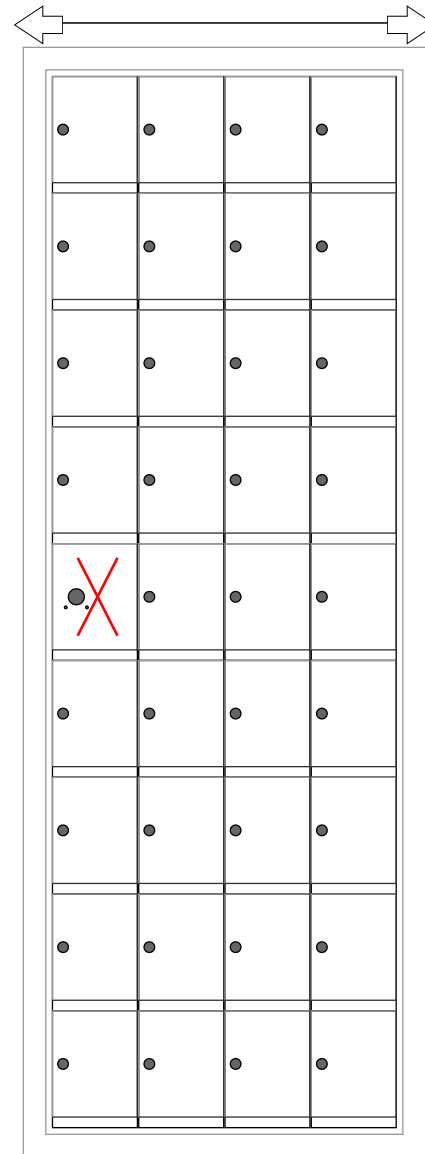

160094

**Side View**

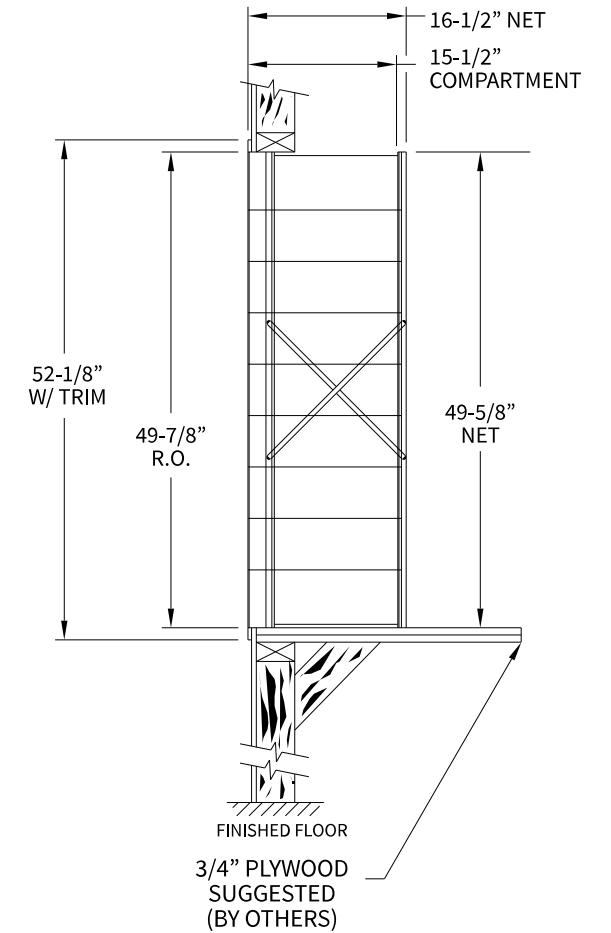

**Configuration Details:**

- 1. **Product Type:** 1600 Horizontal
- 2. **Installation:** Front-load, Recessed Mount
- 3. **Finish:** Anodized Aluminum
- 4. **Locks:** Standard Cam Lock, 2 keys
- 5. **Door Id:** tbd

Matching standard snap-on trim included

**Models Used:**

(1) 160094

**DO NOT SCALE OFF DRAWING**

**Door Sizes Used:**

(35) 1600 1x1 Compartment  
(1) 1x1 Master

**ELEVATION:** 160094 | **MAILBOXES:** 35 |

**PROJECT NAME:** 1600 Series Mailbox | **DRAWN BY:** FLORENCE

**AF FLORENCE**  
manufacturing company

5935 Corporate Drive • Manhattan, KS 66503  
www.florencemailboxes.com • 800.275.1747

A GIBRALTAR INDUSTRIES COMPANY

**DATE:** 01-15-2016

**P.O. NO:**

**SCALE:** NONE

**QUOTE NO:**

**DRAWING NO.** WEB-1932

**SHEET 1 OF 1**