

Before installing your Whitehall mailbox post, Consult MISSDIG at 811, consult your local branch of the US post office for road set-back requirement and height from roadbed or curb. Typically it is required that the front of the mailbox be 6"-8" from the curb/street edge and the floor of the mailbox be 41" to 45" above the street level.

## TOOLS NEEDED

9/16" socket plus socket wrench, pliers or 9/16 wrench, and short handled Philips screw driver, & rubber mallet

## PARTS

- A- 4"x 4" (desired length) Duo Mount Cross Bar with Mailbox through holes
- B- 4"x 4" x 74" Vertical Posts x1
- C- Post End Caps x2
- D- Whitehall Mailboxes x2 (Sold Separately | Capitol & Balmoral options)
- E- Newspaper Tubes x2 (Sold Separately)
- F- #10-24 x 1/2" Pan Head PhilipsScrews x2 (for newspaper tube)
- G- 9/16"x 5.5" Hex Head Bolts (x3)
- H- 9/16" Lock Washers (x3)
- I- 9/16" Hex Nuts (x3)
- J - Hinged Bolt Head Cover (3x) - Black & White, for bronze/green use black

### Balmoral mailbox shown

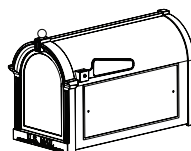
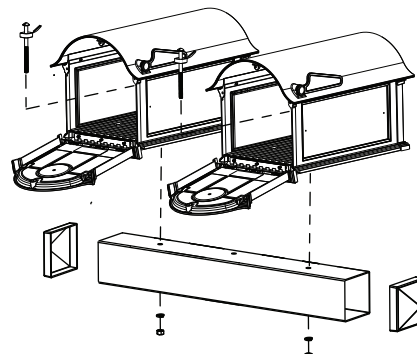

### Capitol mailbox also mounts on cross bar

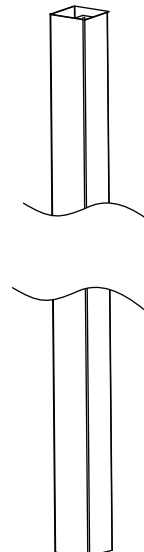

## POST ASSEMBLY:

- 1) Slide a Hinged Bolt Head Cover (J) onto the Hex Head Bolt (G)(see Diag. 1).
- 2) Using one of the Hex Head Bolts with Cover, Attach the Cross Bar (A) onto the Vertical Post (B), making sure to position the cross bar with welded mounting squares facing down (see Diag. 2). Once the Hex Head Bolt has been tightened, close the Hinged Bolt Head Cover.
- 3) Attach the Post End Caps (C) onto the ends of the Cross Bar (A) by placing them over the end of the post and gently tapping into place with rubber mallet (see Diag. 3).

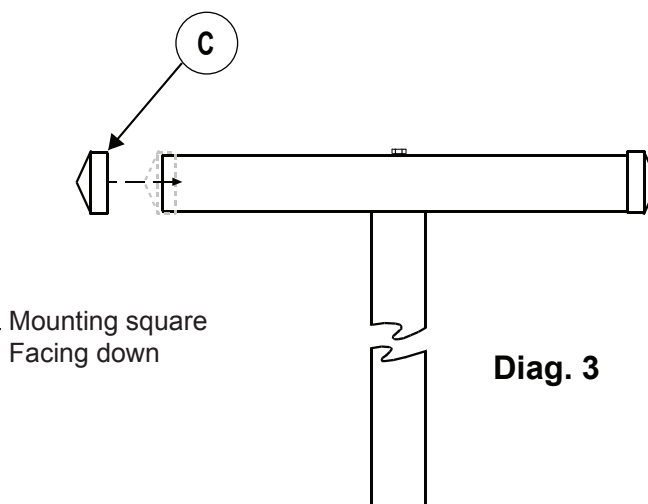
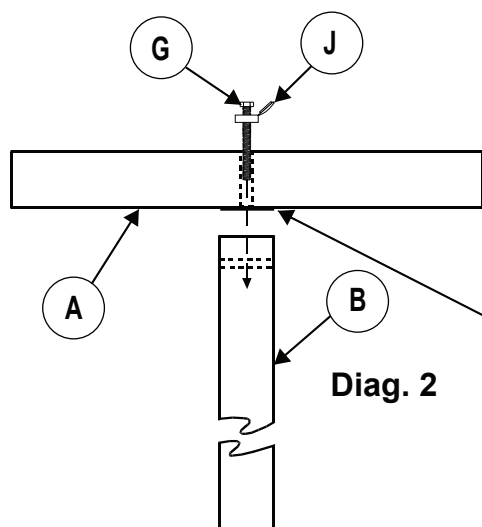
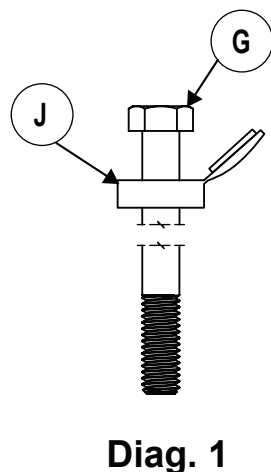

Instructions continued on next of page

## SETTING THE POST INTO THE GROUND

- 1) Consult **MISSDIG at 811** for possible interference with underground utilities. Also consult your local USPS post office for recommended road setback and height requirements in your area.
- 2) Establish a hole 6" - 8" back from road edge, add 9" and mark position on ground for front edge of post.
- 3) Dig 33" to 37" deep, ensure post is parallel to the road and recheck that post is 6" - 8" back from road edge plus 9". (See diag 4)
- 4) Place assembly into holes and partially backfill. Check to ensure cross bar is level and plumb on the vertical post. Check and adjust to postal set back and height requirements.
- 5) Complete back-fill of post holes and pack the earth firmly.  
*Note: for a permanent installation, use concrete mix to back-fill unless it is against USPS or local guidelines or laws.*

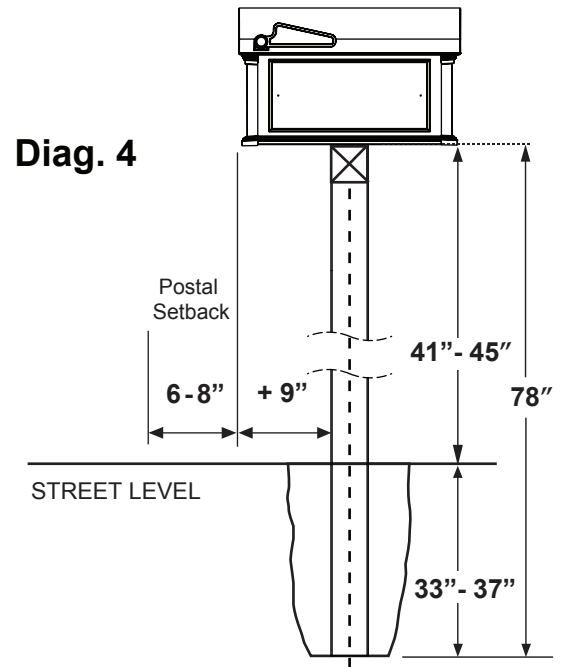

## ATTACHING MAILBOXES ONTO THE POST ASSEMBLY

- 1) Attach your personalized door plaque and/or side plaques to the Mailboxes (D) using the separate instruction sheet provided.
- 2) Set a mailbox (D) on the Cross Bar of the post assembly (A) so that the through holes on the bottom of the mailbox (see image to right) are aligned with the mailbox mounting hole on the top of the cross bar (See diag. 5).
- 3) Slide a Hinged Bolt Head Cover (J) onto the Hex Head Bolt (F)(see diag. 6).
- 4) Reaching inside of the mailbox, insert the 9/16" x 5.5" bolt (F) with Hinged Bolt Head Cover (I) through the hole in the base of the mailbox and down through the Cross Bar (A).

**Note: if you are installing optional newspaper boxes, follow steps 5 & 6. If not, proceed to step 7.**

- 5) From inside of the newspaper box (E), thread the 1/2" pan head screw (J) into the small tapped hole until tight (see diagram 5).
- 6) Push the newspaper box onto the Bolt (G), align the threads of the pan head screw with the appropriate hole in the bottom of the Cross Bar (A) and hold the newspaper box and Cross Bar together (The screw will prevent the newspaper box from rotating).

- 7) Place a Lock Washer (H) and 9/16" Hex Nut (I) onto the bottom of the bolt (G). Using one wrench to keep the Hex Nut from turning, tighten the Hex Head Bolt with a second wrench. Close the Hinged Bolt Head Cover.  
**Repeat steps 1-7 for the second mailbox.**

